

Data Sheet

Oil Motor Pump BFPM Controller

Application

The BFPM range is a series of Danfoss oil pumps in combination with a highly efficient permanent magnet motor, designed for use with small domestic oil burners.

BFPM Electronic Controller must be used for controlling the BFPM motor pumps (see separate data sheets for each BFPM oil motor pump).

BFPM Electronic Controller features:

- One control for all BFPM motor pumps
- Automatic recognition of connected BFPM motor pump
- Built-in diagnostics
- Programmable for specific applications
- PWM signal
- Suitable for connection to electronic compound

Connections

- 1 Motor cable
- 2 Signal cable
- 3 Transducer signal cable
- 4 Transducer cable
- 5 Power cable

Please notice:

- max. permitted cable length is 3000 mm.
- for EMC reason it might be necessary to add ferrite cores on the power supply cable and the motor cable.
- the controller must be mounted under a cover, where tools are needed to get access.

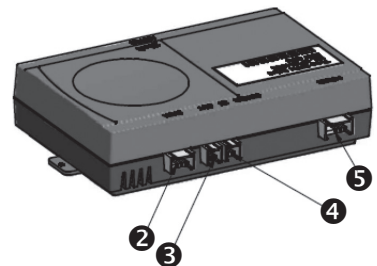
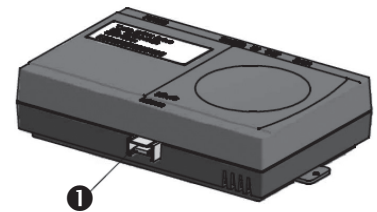

- P₁**: Pressure relief valve/regulator
- S**: Suction inlet G1/4
- R**: Return outlet G1/4
- E**: Nozzle outlet G1/8
- P**: Pressure gauge port G1/8
- V**: Vacuum gauge port G1/8
- H**: Filter
- PT**: Pressure transmitter
- O**: Constriction
- A**: 2-pipe screw

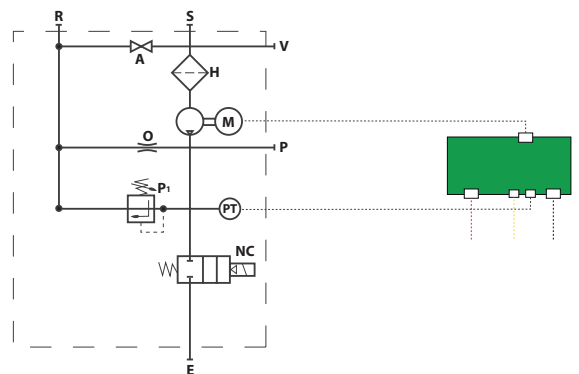

Technical Data

Safety	Galvanic isolated from high voltage side (supply voltage and motor) to signal side
Humidity	Below 95% r.h. (non-condensing)
Lifetime	Min. 10 years operating, equal to 20,000 hours
Operating temperatures	0 to 60° C
Storage temperature	-20 to 60° C
TÜV approval	According to EN/IEC 60335-1

Operating Mode

Fixed Speed

- ❶ Motor control box (MCB)
- ❷ Motor cable
- ❸ Power cable from Burner Control Box (BCB)

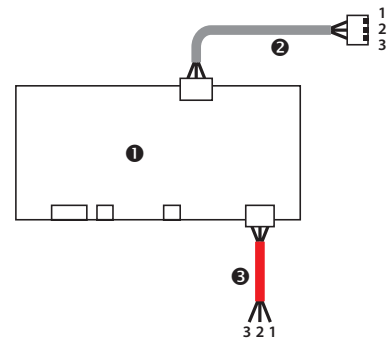

Cable	Terminal	Colour	Type	Line	Description	Function	Remarks
Power ❸	1	brown	Input	L	230 V, 50 Hz	Power supply	From Burner Control Box (BCB)
	2	yellow/green		PE	Protection		
	3	blue		N	0		
Motor ❷	1	brown	Internal	W	230 VAC	Motor power supply and drive	
	2	blue		V			
	3	black		U			

Variable Speed

- ❶ Motor control box (MCB)
- ❷ Motor cable
- ❸ Power cable from Electronic Control Box (ECB)
- ❹ Control signal cable from Electronic Control Box (ECB)

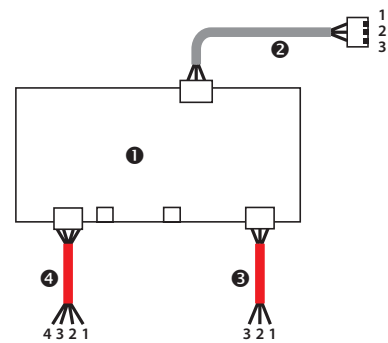

Cable	Terminal	Colour	Type	Line	Description	Function	Remarks
Control signal ❹	1	white	input	+	4-12 VDC, 50 Hz PWM	Set point speed	Optocoupled, galvanic isolated
	2	yellow		-			
	3	green	output	+	Open collector, 50 Hz PWM	Feedback speed	Optocoupled*, RS 220 Ω, <25 mA
	4	brown		-			
Power ❸	1	brown	Input	L	230 V, 50 Hz	Power supply	From Electronic Control Box (ECB)
	2	yellow/green		PE	Protection		
	3	blue		N	0		
Motor ❷	1	brown	Internal	W	230 VAC	Motor power supply and drive	
	2	blue		V			
	3	black		U			

*SFH 6156-3

Pressure Modulation

- ❶ Motor control box (MCB)
- ❷ Motor cable
- ❸ Power cable from Electronic Control Box (ECB)
- ❹ Control signal cable from Electronic Control Box (ECB)
- ❺ Transducer signal cable from Electronic Control Box (ECB)
- ❻ Transducer cable

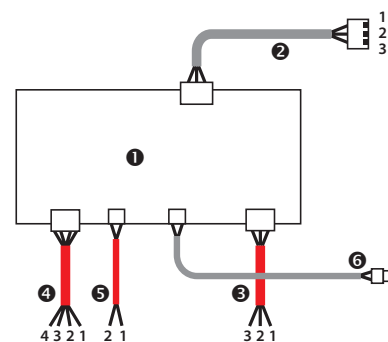

Cable	Terminal	Colour	Type	Line	Description	Function	Remarks
Control signal ❹	1	white	input	+	4-12 VDC, 50 Hz PWM	Set point pressure	Optocoupled, galvanic isolated
	2	yellow		-			
	3	green	output	+	Open collector, 50 Hz PWM	Feedback speed	
	4	brown		-			
Transducer signal ❺	1	black	output	supply +	4-20 mA, max. 100 Ω	Transducer signal	Direct transducer signal
	2	red		supply -			
Power ❸	1	brown	Input	L	230 V, 50 Hz	Power supply	From Electronic Control Box (ECB)
	2	yellow/green		PE	Protection		
	3	blue		N	0		
Transducer ❻	1	yellow	Internal	supply +	9-28 V	Pressure measurement	0-28 bar, 4-20 mA, galvanic isolated
	2	blue		supply -			
Motor ❷	1	brown	Internal	W	230 VAC	Motor power supply and drive	
	2	blue		V			
	3	black		U			

*SFH 6156-3

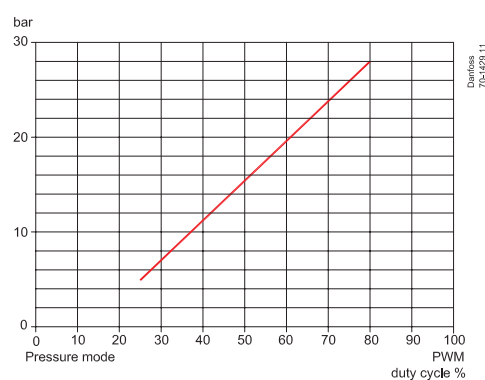
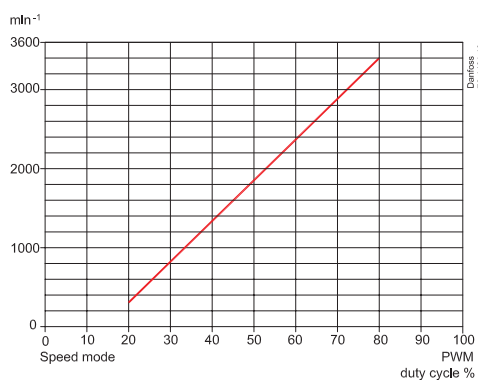

Note! Fix speed mode 2800 min⁻¹

Diagnosics

The BFPM status is indicated by green, yellow and red LED's: ● = LED off, ○ = LED on (●/○= 250 ms)

Note! The LED's are placed under the cover.

Warning! 230 V on print circuit board.

	Green (power)	Yellow (motor OFF/motor ON)	Red (error)
Power OFF	●●●●●●●●	●●●●●●●●... / ●●●●●●●●...	●●●●●●●●
Power ON	○○○○○○○○	○●●●○●●●... / ○○●●○○●●...	see Error Indication

Error	Limits	Class B	Reaction	Error state	Output	Comment	Error indication
Under-voltage	<150 V	no	stop motor, restart > 160 V	1	25 Hz, 20% duty	Undervoltage	○●●●○●●●●●●...
Motor overload		yes	stop motor, wait 10 sec., restart	2	25 Hz, 30% duty	Motor overload	○●○○●●●○●○○●●●...
Rotor blocked		yes	stop motor, 5 start attempts, wait 10 sec., restart	2	25 Hz, 30% duty	Pump defect	○●○○●●●○●○○●●●...
Wrong offset value	Offset value for current measurement circuit must be in allowed range of 35-51 mV	no	check before motor start (motor will not start if value is outside allowed range)	2	25 Hz, 30% duty	Stator failure	○●○○●●●○●○○●●●...
RAM failure		yes	stop motor, wait for power down	3	25 Hz, 40% duty	Failure in electronics	○●○○●●●○●○○●●●...
ROM failure							
Register failure							
Stack failure							
CPU crystal failure							
Motor phase broken		yes	stop motor, wait for power down	4	25 Hz, 50% duty	Stator defect, check wiring	○●○○●●○●●●●●...
Pressure transducer	Pump running current ranges outside 3.5 mA > current < 23mA	yes	stop motor, wait for power down	5	25 Hz, 60% duty	Transducer signal failure	○●○○●●○●●●●●...
Pressure transducer initialisation	Current range outside 3.5 mA > current < 5mA	yes	stop motor, wait for power down	5	25 Hz, 60% duty	Transducer defect / wiring problem	○●○○●●○●●●●●...
PWM input failure	< 47 Hz or > 53 Hz, < 10% or > 90% duty	yes	stop motor, wait for power down	6	25 Hz, 70% duty	If missing PWM signal, stop motor and wait for PWM burner control to start. PWM input signal failure.	○●○○●●○●●●●●...

Dimensions

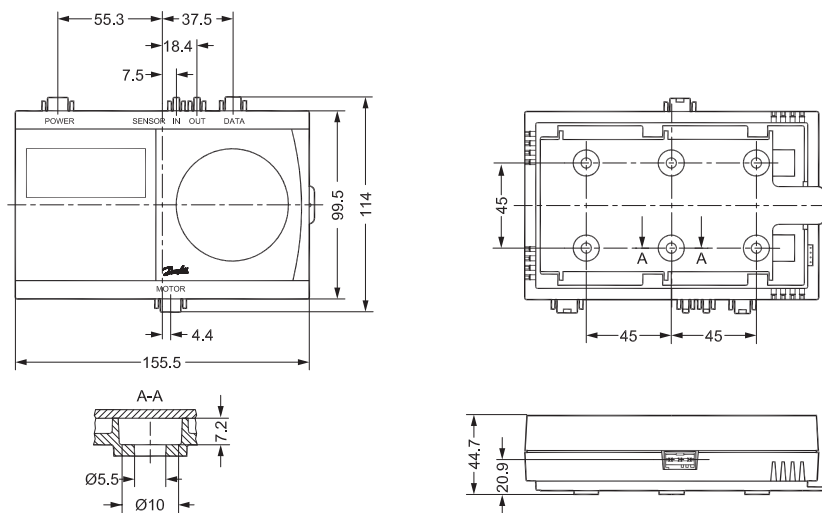

Danfoss 71001.11

www.burner.danfoss.com

Danfoss can accept no responsibility for possible errors in catalogues, brochures and other printed material. Danfoss reserves the right to alter its products without notice. This also applies to products already on order provided that such alterations can be made without consequential changes being necessary in specifications already agreed. All trademarks in this material are property of the respective companies. Danfoss and the Danfoss logotype are trademarks of Danfoss A/S. All rights reserved.