

MKP-6 Kelvin Probe



MKP-6 Probe with "B" Style Pin Installed

Ideal for precision resistance measurements* in tighter spaces. The probes are marked indicating the sense pins, ensuring an operator error free measurement. The test leads are 6 feet long and are terminated with dual banana plugs. Variety of probe tips available. Pin center to pin center is 0.11 in (0.28 cm).

Cable length - 6 ft

Max Voltage and Current Rating - 42 V, 2 A

Typical Sense Lead Resistance - 225 mΩ

Typical Source Lead Resistance - 100 mΩ

Available Pin Options: P/N MKP-B, MKP-F, MKP-H, MKP-J, MKP-LM (4 pins) (shown right)

(Pins are not included with the probe set and need to be ordered separately.)

Compatible with TEGAM R1L-B, R1L-BR, R1L-BR1, R1L-D1

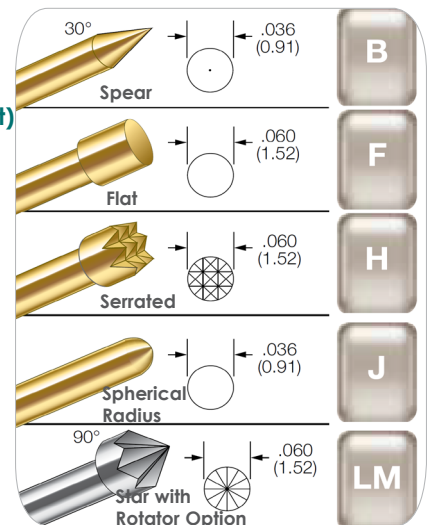

MKP-6 Pin Options

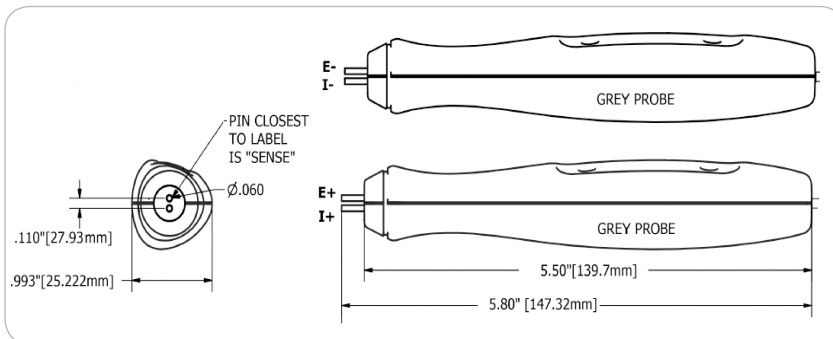

MKP-6 Probe Dimensions

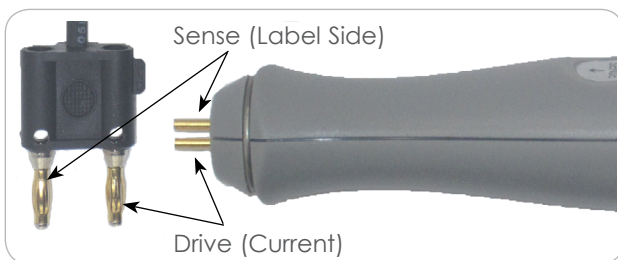

MKP-6 Pinout Information

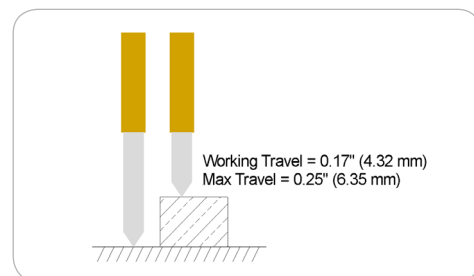

MKP-6 Pin Travel

*Consider the affects of Thermal offsets on your measurement. Offset compensation may be required to achieve the desired results. Contact TEGAM for more information. Sourcing through the "Sense" leads may have ill effects on the reading, and may damage the probes.

VOLTAGE AND RESISTANCE PRODUCTS

To replace the tips:

1. Grab the replaceable probe tip from the plunger. Do not grab the socket, or damage to the probe may occur. Pull the tip straight out with pliers.

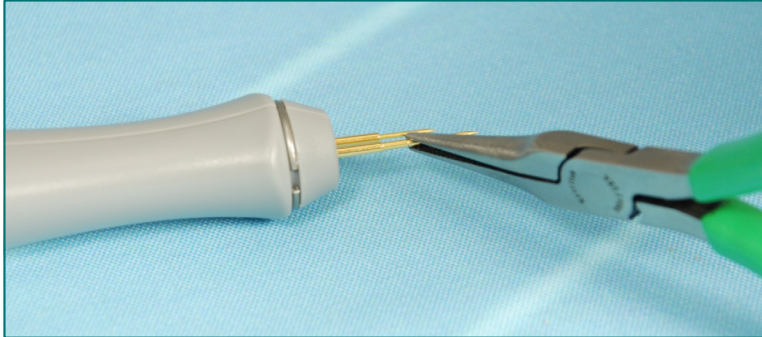

2. To fully install the new pin, position the new pin in the socket and press it against a hard surface.

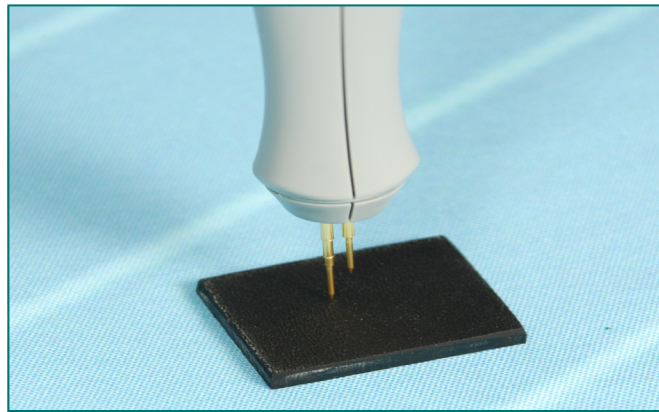
**Optional Probe Configurations
Offered by TEGAM**