

Data sheet

Actuators for modulating control

AME 130, AME 140, AME 130H, AME 140H

Description

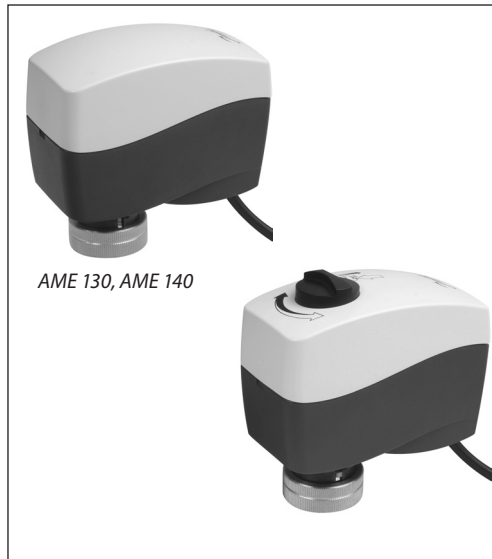

AME 130, AME 140, AME 130H and AME 140H actuators are used with:

- VZ DN 15, 20,
- VZL DN 15, 20 with stem extension plug or
- AHQM (DN 15-32) valves.

The actuator can be used with fan coil units, induction units, small reheaters, recoolers, and zone applications in which hot/cold water is the controlled medium.

Main data:

- Modulating control
- Force switch-off at stem down position prevents overload of actuator and valve.
- No tools required for mounting
- Maintenance free during lifetime
- Low noise operation
- Self-positioning process
- Supplied with 1.5 m cable

Ordering

Type	Supply voltage (V AC)	Speed (s/mm)	Code No.
AME 130	24	24	082H8044
AME 140		12	082H8045
AME 130H		24	082H8046
AME 140H		12	082H8047

Spare parts

Type	Code No.
Cable (5 m)	082H8052

Technical data

Type		AME 130, AME 130H	AME 140, AME 140H
Power supply	V	24 AC; +10 to -15%	
Power consumption	VA	1.3	
Frequency	Hz	50/60	
Control Input Y	V	0-10 (2-10) [Ri = 200 kΩ]	
	mA	0-20 (4-20) [Ri = 500Ω]	
Closing force	N	200	
Max. stroke	mm	5.5	
Speed	s/mm	24	12
Max. medium temperature inside the pipe		130	
Ambient temperature	°C	0 ... 55	
Storage and transport temperature		-40 ... 70	
Ambient humidity		95 % r.h., non-condensing	
Protection Class		III safety extra-low voltage	
Grade of enclosure		IP 42	
Weight	kg	0.3	
CE - marking in accordance with standards		Low Voltage Directive (LVD) 2014/35/EU: EN 60730-1, EN 60730-2-14 Electromagnetic Compatibility Directive (EMC) 2014/30/EU: EN 61000-6-2, EN 61000-6-3	

Installation

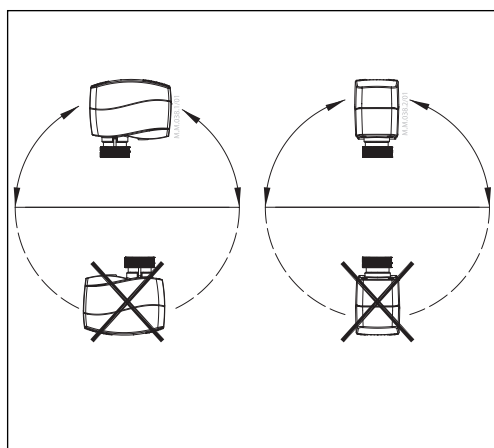

Mechanical

The actuator should be mounted with the valve stem in either horizontal position or pointing upwards.

The actuator is fixed to the valve body by means of a mounting ring which requires no tools for mounting. The ring should be tightened by hand.

Electrical

Important: It is strongly recommended that the mechanical installation is completed before the electrical installation.

Each actuator is supplied with the connecting cable for the controller.

Disposal

The actuator must be dismantled and the elements sorted into various material groups before disposal.

Wiring

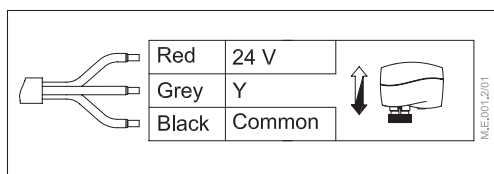

Commissioning

The factory setting of the spindle is the fully stem up position because of easier mechanical connection of the actuator on the valve.

Installation procedure

- 1 Check the valve's neck. The actuator should be in stem up position (factory setting). Ensure that the actuator is mounted securely on valve body.
- 2 Energise the actuator according to the wiring diagram 2.
- 3 The direction of stem movement can be observed on the position indicator.

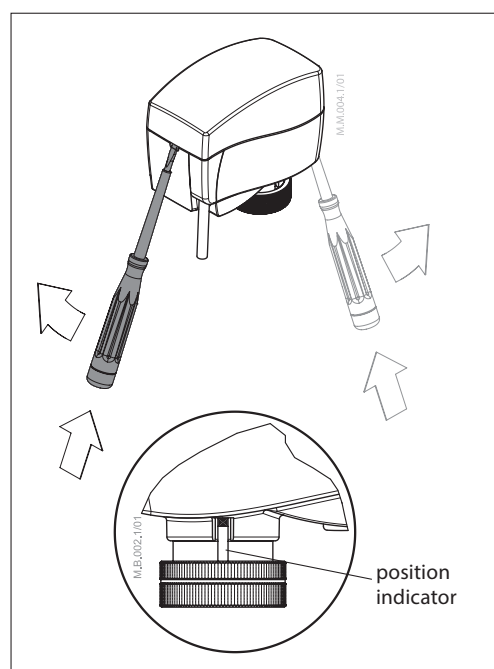

**DIP Switch Setting
(for service purposes only)**

The actuator has a function selection DIP switch under the removable cover.

The switch provides the following functions:

- SW1:
Reset
Changing this switch position will cause the actuator to go through a self stroking cycle.
- SW2:
0/2 - Input signal range selector
If set to OFF position, the input signal is in the range from 2 -10 V (voltage input) or from 4-20 mA (current input). If set to ON position, the input signal is in the range from 0-10 V (voltage input) or from 0-20 mA (current input).
- SW3:
D/I - Direct or inverse acting selector
If set to OFF position, the actuator is direct acting (stem lowers as voltage increases). If the actuator is set to ON position, the actuator is inverse acting (stem raises as voltage increases).
- SW4:
---/Seq - Normal or sequential mode selector:
If set to OFF position, the actuator is working in range 0(2)-10V or 0(4)-20mA. If set to ON position, the actuator is working in sequential range; 0(2)-5 (6)V or 0(4)-10 (12)mA or (5(6)-10V) or (10(12)-20mA).

- SW5:
0 ... 5 V/5 ... 10 V - Input signal range in sequential mode:
If set to OFF position, the actuator is working in sequential range 0(2)-5 (6)V or 0(4)-10 (12) mA. If set to ON position, the actuator is working in sequential range; 5(6)-10V or 10(12)-20mA.
- SW6:
U/I - Input signal type selector
If set to OFF position, voltage input is selected. If set to ON position, current input is selected.

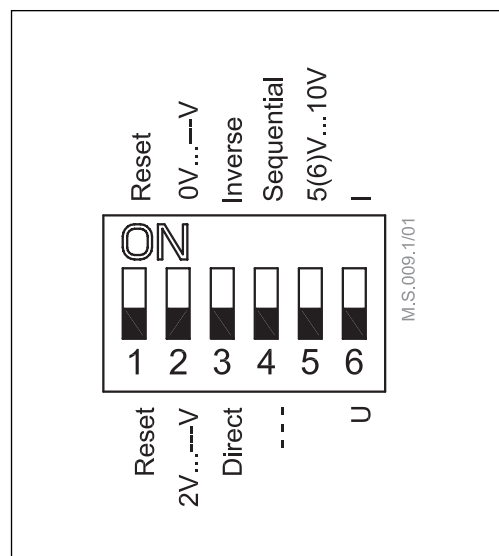

**Manual override
(for service purposes only)**



Caution:
Do not manually operate the drive under power!

AME 130, AME 140

- 1 Remove the cover.
- 2 Insert the Allen key 6 into the spindle.
- 3 Press and hold the button (on the bottom side of the actuator) during manual override.
- 4 Pull out the tool.
- 5 Place cover back on the actuator.

Remark:
A "click" sound after energizing the actuator means that the gear wheel has jumped into normal position.

If manual override has been used, then Y signal is not correct until the actuator reaches it's end position. If this is not accepted, reset the actuator.

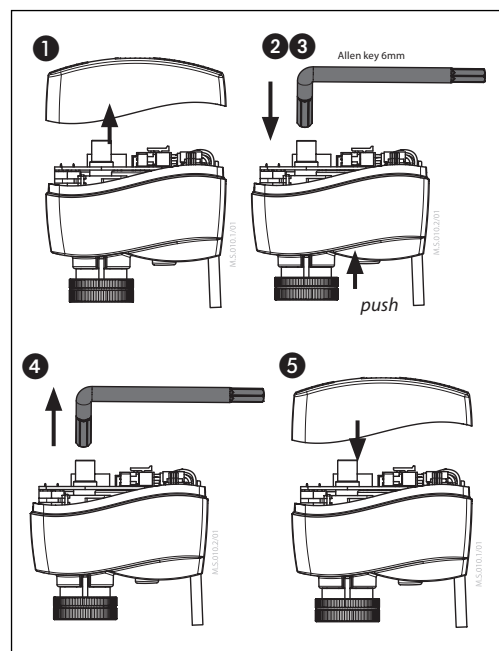

Data sheet

AME 130, AME 140, AME 130H, AME 140H

Manual override
(continuous)

AME 130H, AME 140H

- 1 Press and hold the button (on the bottom side of the actuator) during manual override.

Remark:

A "click" sound after energizing the actuator means that the gear wheel has jumped into normal position.

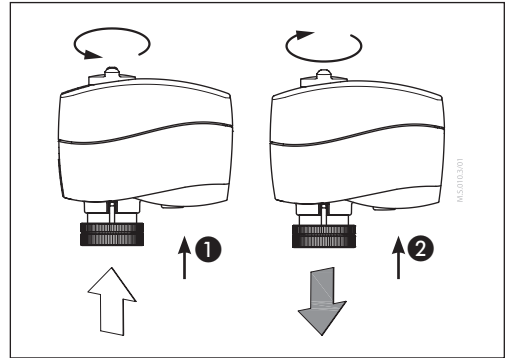

Actuator - valve combinations

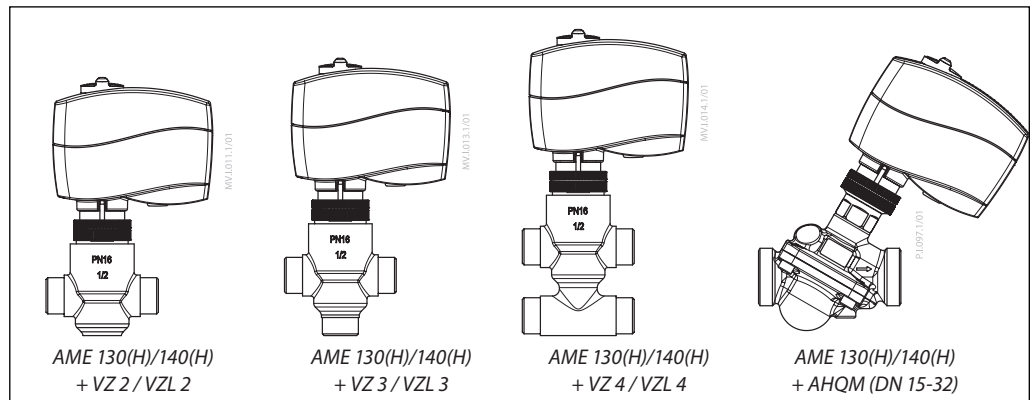

Remark: VZL valves with stem extension plug

Dimensions

