

EL 3

Conductive multiple rod electrode



Application area

The multiple rod electrode EL 3 is a universal level switch for conductive liquids. The instrument is ideal as overflow and dry run protection in conjunction with VEGATOR 256C and VEGATOR 632 signal conditioning instruments.

Your benefit

- Simple setup with minimum time and cost expenditure
- High flexibility in use through shortenable probe
- Maintenance-free through robust design

Function

The instruments are used for level detection in conductive liquids. A VEGATOR 256 C or 632 is required for operation of the conductive probe. When the probe is immersed, a slight alternating current flows and is detected, evaluated and converted into a switching command by the signal conditioning instrument. The switching point is determined via the mounting position or the length of the respective probe.

Technical data

Probe length	up to 6 m (19.69 ft)
Conductance of the medium	min. 7.5 μ S/cm
Process fitting	Thread G1½
Process pressure	-1 ... +63 bar/-100 ... +6300 kPa (-14.5 ... +914 psig)
Process temperature	-50 ... +130 °C (-58 ... +266 °F)
Ambient, storage and transport temperature	-40 ... +80 °C (-40 ... +176 °F)
Voltage supply	Via the connected signal conditioning instrument

Materials

The wetted parts of the instrument are made of stainless steel. The probe insulation is made of PTFE. You will find a complete overview of the available materials and seals in the "configurator" on our homepage at www.vega.com/configurator.

Housing versions

The housing is made of stainless steel. The housing cover of plastic (PBT). It is available with protection rating up to IP 66/IP 67.

Electronics versions

The probe is operated with external processing. The connected signal conditioning instrument powers the probe and provides a switching signal.

Approvals

The instruments are suitable for use in hazardous areas and are approved according to ATEX. You can find detailed information on the existing approvals in the "configurator" on our homepage at www.vega.com/configurator.

Operation

You can find the setup procedure for EL 3 in the operating instructions manual of the corresponding signal conditioning instrument.

Electrical connection

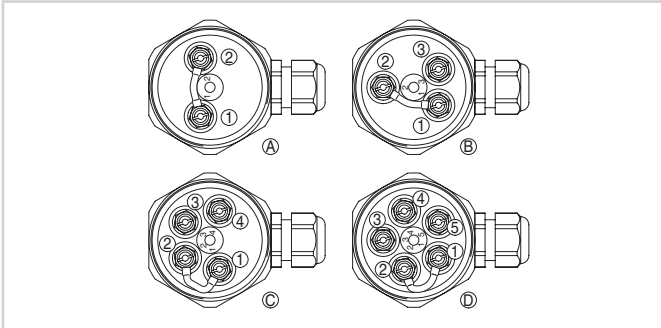

Connection compartment of the probe - 220 kΩ resistance between terminals 1 and 2

- 1 Connection terminal 1 = longest probe
- 2 Connection terminal 2 = shortest probe
- A Probe with 2 measuring electrodes
- B Probe with 3 measuring electrodes
- C Probe with 4 measuring electrodes
- D Probe with 5 measuring electrodes

You can find details on electrical connection in the instrument operating instructions on our homepage at www.vega.com/downloads.

Dimensions

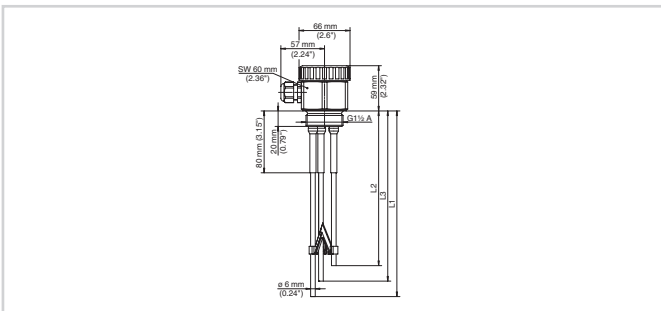

Conductive probe EL 3

L1-3 Probe length

Information

You can find further information on the VEGA product line on our homepage www.vega.com.

In the download section under www.vega.com/downloads you'll find free operating instructions, product information, brochures, approval documents, instrument drawings and much, much more.

Instrument selection

With the "Finder" at www.vega.com/finder and "VEGA Tools" you can select the most suitable measuring principle for your application. You can find detailed information on the instrument versions in the "Configurator" at www.vega.com/configurator and "VEGA Tools".

Contact

You can find the VEGA agency serving your area on our homepage www.vega.com.