

**TEST GAUGE MANUFACTURED AT OUR PLANT
MODEL 300**

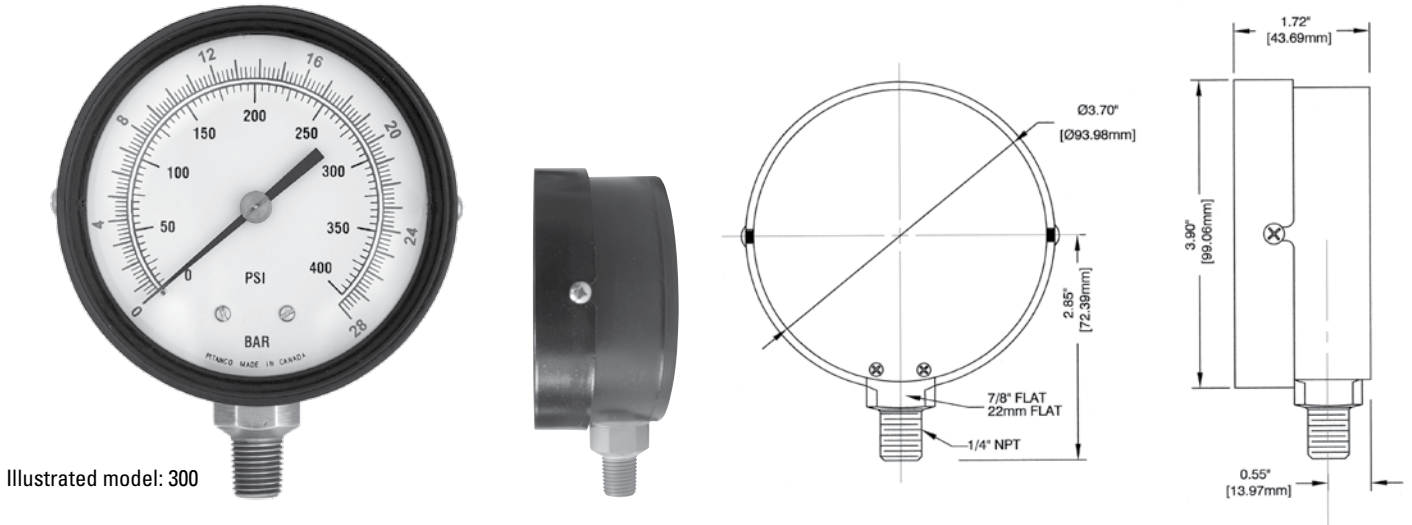

Illustrated model: 300

Specifications

Case:	4 in (100 mm), black molded aluminum
Dial:	White aluminum, graduations in black
Unit of measure:	Standard psi, other units of measure available
Custom dial:	Private logo available
Ring:	Black molded aluminum
Lens:	Polycarbonate or glass
Pointer:	Anodized black aluminum, micro adjustable
Connection:	1/4 in nptm bottom
Wetted parts:	Brass
Bourdon tube:	Phosphor bronze
Maximum process and ambient temperature:	-40 to 150°F / -40 to 65°C
Operating pressure:	Maximum 75 % of full scale value
Overpressure limit:	25 % over full scale value
Accuracy:	ASME B40.100(B40.1), Grade 2A ± 0.5 %

Applications

Designed for increase accuracy. To be used where accuracy and repeatability are of the utmost importance. Used in laboratories and industries that require precise measurement. Manufactured entirely at our facility in Delson, Qc. Calibration test certificates traceable to NRC and NIST are available.

To order, use the code in the corresponding column

Range	Product code
-30 in Hg vaccum	300-01
0 to 15 psi	300-09
0 to 30 psi	300-10
0 to 60 psi	300-11
0 to 100 psi	300-12
0 to 160 psi	300-13
0 to 200 psi	300-14
0 to 300 psi	300-15
0 to 400 psi	300-23
0 to 600 psi	300-16
0 to 1,000 psi	300-17
0 to 2,000 psi	300-22