

Data sheet

CI-tronic™ Soft Start Motor Controller

Type MCI 25B with Brake



MCI 25B motor controller with brake is designed for soft starting and braking of 3 phase AC motors.

The digital controlled soft starter features accurate settings and several monitoring functions. Acceleration time and initial torque are along with the braking torque easily adjusted. During braking the MCI 25B will apply a DC current to all the windings of the motor, thus providing a powerful brake function. The automatic stop detection ensures a safe operation. For positioning applications the unique slow speed function can be applied.

The MCI 25B controller is typically applied on demanding braking applications such as saws, cranes, automatic doors, etc.

Features

- Adjustable acceleration time, 0 – 10 seconds
- Initial torque adjustable from 0 – 85%, with or without kick start (break-away)
- Adjustable DC injection brake, 0 – 50 A DC
- Fast acting brake mode with automatic motor field reduction
- Automatic stop detection
- Universal control voltage 24 – 480 V AC/DC
- Slow speed function, 7.5% or 10% of nom. speed
- SCR aux. contacts for external control of by-pass, I-O and mechanical brake
- Automatic detection of missing phase(s)
- Automatic adaptation to 50/60 Hz
- Unlimited start and stop per hour
- IP 20 protection
- Compact DIN rail mountable design
- EN 60947-4-2
- CE, C-tick

Adjustments

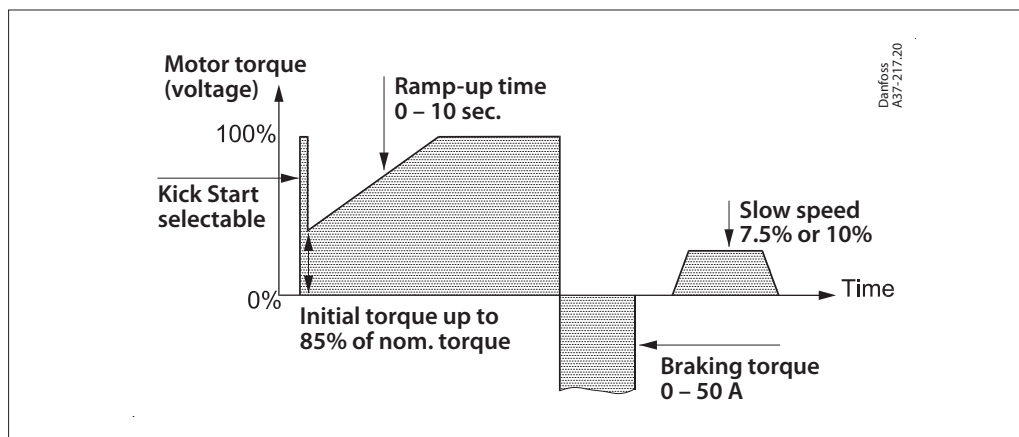

Selection guide

Operational voltage	Motor current	Motor power	Control voltage	Module dimensions	Code no.
[V AC]	[A]	[kW/HP]	[V AC/DC]	[mm]	
208 - 240	25	7.5/10	24 - 480	90	037N0061
380 - 480	25	1/15	25 - 480	90	037N0062

Technical data
Control circuit specifications

Control voltage range	24 – 480 V AC/DC
Pick-up voltage max.	20.4 V AC/DC
Drop-out voltage min.	5 V AC/DC
Max. control current for no operation	1 mA
Control current / power max.	15 mA / 2 VA
Response time max.	70 ms
Ramp-up time	Adjustable from 0 to 10 Sec.
Brake current	Adjustable from 0 to 50 A
Initial torque	Adjustable from 0 to 85 % of nominal torque with optional kick start
SCR aux. contacts, voltage/current max.	24 – 480 V AC / 0.5 A (AC-14, AC-15)
SCR aux. contacts, max. fuse	10 A gL/gG, I ² t max. 72 A ² s
Design standard	CE marked according to EN 60947-4-2
EMC immunity	Meets requirements of EN 50082-1 and EN 50082-2

Output Specifications

Operational current max. (AC-3, AC-53a)	25 A
Motor size at: 208 – 240 V AC 380 – 480 V AC	0.7 – 7.5 kW (1 – 10 HP) 1 – 11 kW (1.5 – 15 HP)
Leakage current max.	5 mA
Minimum operational current	50 mA
Overload relay trip class	Class 10
Semiconductor protection fusing Type 1 co-ordination Type 2 co-ordination I ² t (t = 10 ms)	80 A gL/gG 6300 A ² S
Rating index	Slip ring motors: 25A: AC-52a: 4-13: 100-3000 Asynchronous motors: 25A: AC-53a: 8-3: 100-3000

Insulation

Rated insulation voltage, U _i	660 V AC
Rated impulse withstand voltage, U _{imp}	4 kV
Installation category	III

Thermal Specification

Power dissipation for continuous duty P _d max.	2 W/A
Power dissipation for Intermittent duty P _d max.	2 W/A x Duty cycle
Ambient temperature range	-5 °C – 40 °C
Cooling method	Natural convection
Mounting	Vertical +/- 30 °C
Max. ambient temperature with limited rating	60 °C, see derating for high temperatures in chart below
Storage temp. range	-20 °C – 80 °C
Protection degree/pollution degree	IP 20 / 3

Materials

Housing	Self extinguishing PPO UL94V1
Heatsink	Aluminum black anodized
Base	Electroplated steel

Functions

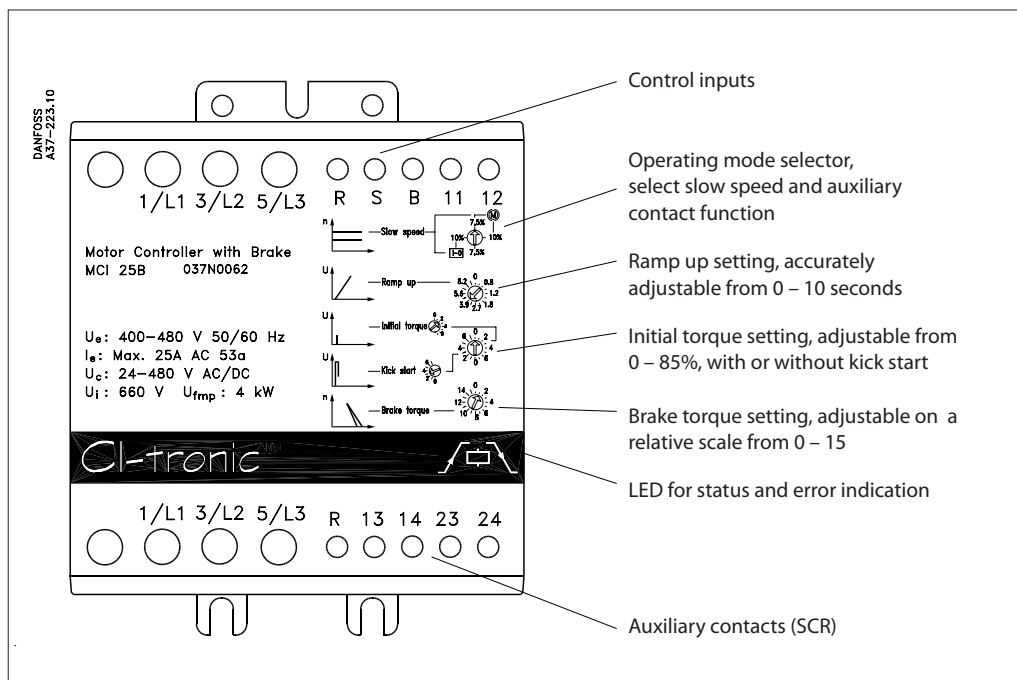

Functional diagram

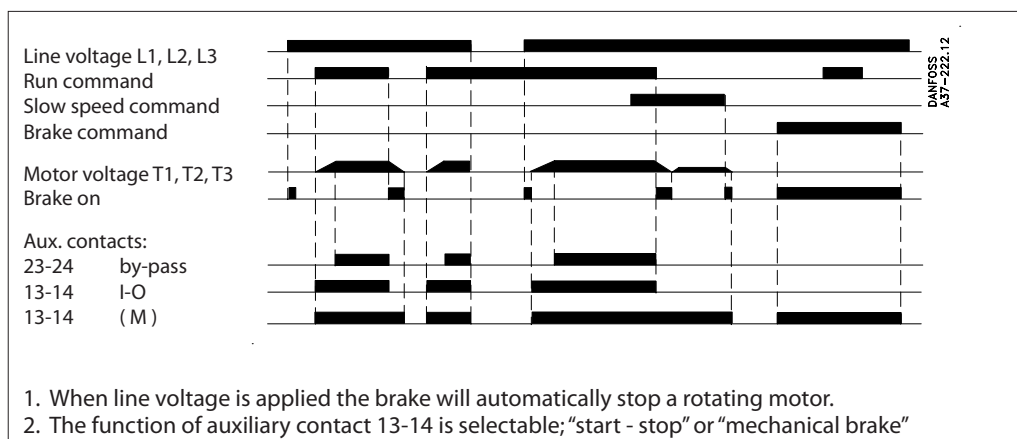

Soft start function

Ramp up

During ramp-up the controller will gradually increase the voltage to the motor until it reach full line voltage. The motor speed will depend on the actual load on the motor shaft. A motor with little or no load will reach full speed before the voltage has reached its maximum value.

The actual ramp time is digitally calculated and will not be influenced by other settings, net frequency or load variations.

Initial torque

The initial torque is used to set the initial starting voltage. This way it is possible to adapt the controller to an application requiring a higher starting torque. In some cases on application with very high break-away torque the initial torque can be combined with a kick start function. The kick start is a period of 200 ms where the motor receives full voltage.

Brake function

Braking is achieved by injecting a DC current, adjustable from 0 – 50 A, onto all the windings of the motor. The brake can be used on both star and delta connected motors, but is most efficient if the motor is connected in star.

Note: If a contactor is placed between motor and the MCI-B, do not open during braking as it can cause the contactor to fail.

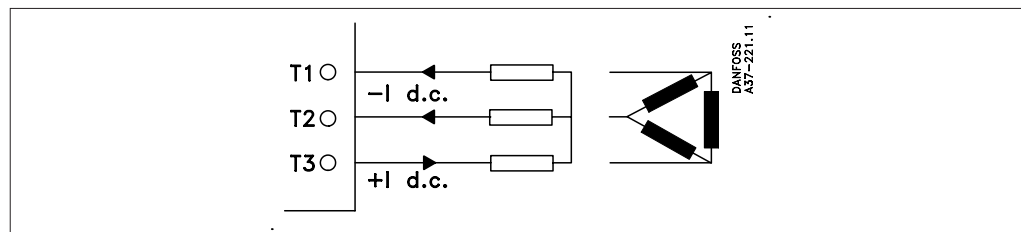

Adjustment

The actual braking torque is controlled indirectly by adjusting the braking voltage. The braking voltage can be set for 0 – 15. For small motors a relatively high braking voltage is necessary contrary to larger motors where a relatively low voltage is sufficient. For this reason the braking voltage must be adjusted to the actual application. Before starting up a new application set the Braking torque to 1. Increase incrementally until desired braking time is reached.

If the motor does not stop within 30 seconds the DC brake will disengage and the controller will show a “brake failure” condition.

The automatic stop detection is accomplished by sensing the DC brake current on the motor, and as so the accuracy of the stop detection will depend on a correctly adjusted brake. The point of “no rotation” depends on the motor size and the brake voltage setting. If the motor voltage is set to low the brake will be switched off before the motor has come to a complete stop. However, if the brake voltage is set to high, out of detection range, it will not switch off the motor before the brake failure conditions occurs after 30 seconds.

Automatic stop detection

When the brake function is applied the MCI-B will bring the motor to a stop before releasing the brake current.

Slow speed function

The slow speed function is intended for short time operation in applications where an exact positioning is needed, for example cranes. The function has two selectable slow speeds: 7.5% or 10% of nominal speed.

The torque level will depend on the motor and selected slow speed, typically 25 – 40% of nominal torque. During slow speed the motor current will increase, typically 2 – 2.5 times the nominal current.

Auxiliary contacts

The auxiliary contacts are made possible by means of SCR technology and will only switch correctly on AC current.

If “Mechanical brake” is selected, the contact will be closed as long as the motor is rotating. The “Mechanical brake” setting is intended for operating an external mechanical brake.

Contact 13-14

The contact 13-14 is selectable for two different functions; “I-O” or “Mechanical brake”. If the “I-O” is selected, the contact will be closed as long as a RUN command is given, see functional diagram

Contact 23-24

The contact 23-24 is intended for operating an external by-pass contactor. The contact will close when the controller is in steady state operation, see functional diagram.

LED status indication

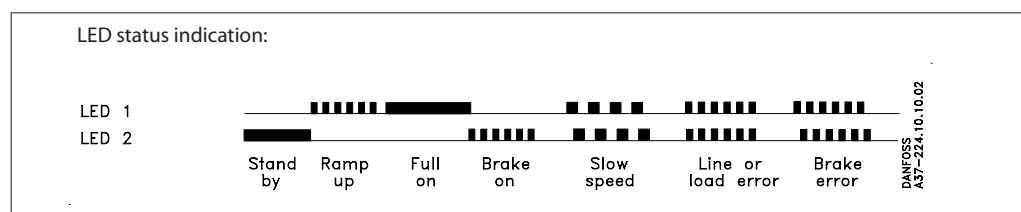

Wiring

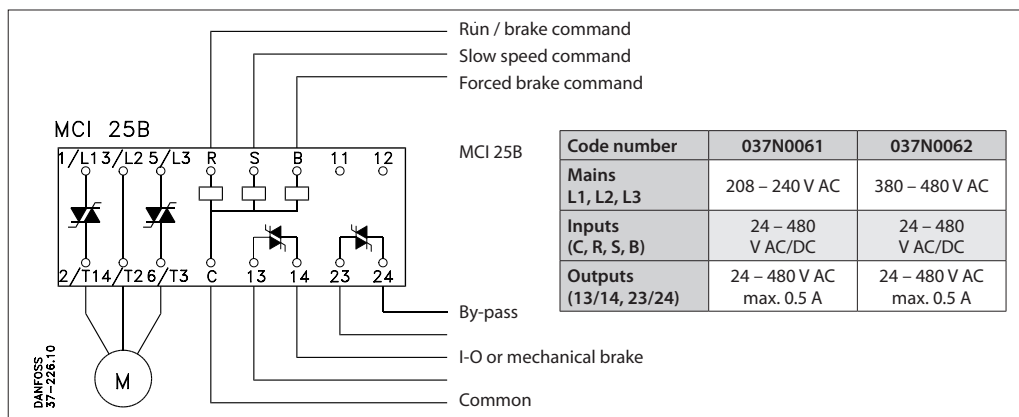

Overload and short circuit protection

Overload and short circuit protection is easily achieved by installing a circuit breaker on the line side of the motor controller. Select circuit breaker from the table according to motor full load current.

Be aware of the maximum prospective short circuit current breaking capacity. For further information please refer to data sheet for the circuit breaker.

380 – 415 V AC

Type	Motor full load current [A]	Max. prospective short-circuit current I _{cc}		Code no.
		Co-ordination ¹⁾ [kA]		
CTI 25M	4.0 – 6.3	100		047B3148
CTI 25M	6.3 – 10	100		047B3149
CTI 25M	10 – 16	40		047B3150
CTI 25M	14.5 – 20	1.8		047B3151
CTI 25M	18 – 25	1.5		047B3152

¹⁾ Values based on let-through curves for appropriate circuit breaker

Dimensions mm (inches)

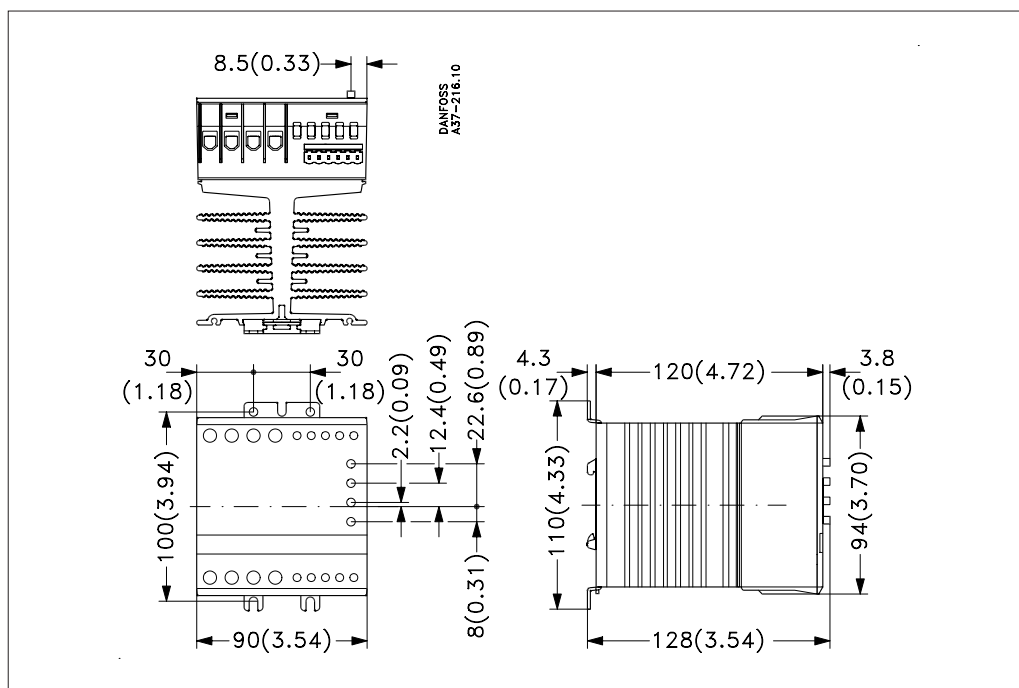

Operating at high temperatures

Operation in temperatures from 40 °C up to 60 °C is possible if the power dissipation is limited

either by reducing the current or by reducing the ON-time of the controller. Refer to table.

Ambient temperature [°C]	Continuous operation [A]	Duty-cycle rating
50	20	25 A with 80% duty cycle, max. on-time 15 min
60	15	25 A with 65% duty cycle, max. on-time 15 min

Operating on heavy loads

Load data is given for normal starts. If applied on heavy starts please derate according to table.

Overload relay trip class	Max. current
	[A]
10 (Light starts)	25
10 (Normal starts)	25
20 (Heavy starts)	20
30 (Very Heavy starts)	15

Overheat protection

If required the controller can be protected against overheating by inserting a thermostat in the slot on the right-hand side of the controller.

Order: UP 62 thermostat 037N0050

For wiring connections see application examples.

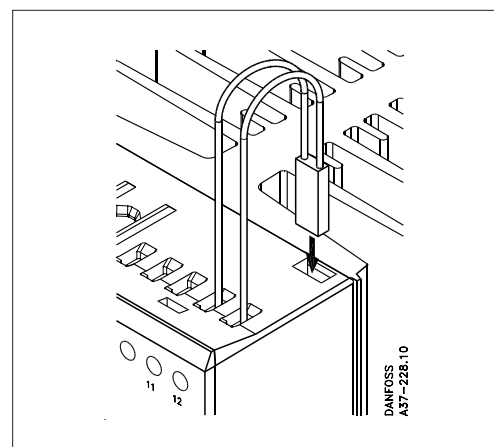

Mounting instructions

The controller is designed for vertical mounting. If the controller is mounted horizontally the load current must be reduced by 50%.

The controller needs no side clearance.

Clearance between two vertical mounted controller must be minimum 80 mm (3.15").

Clearance between controller and top and bottom walls must be minimum 30 mm (1.2").

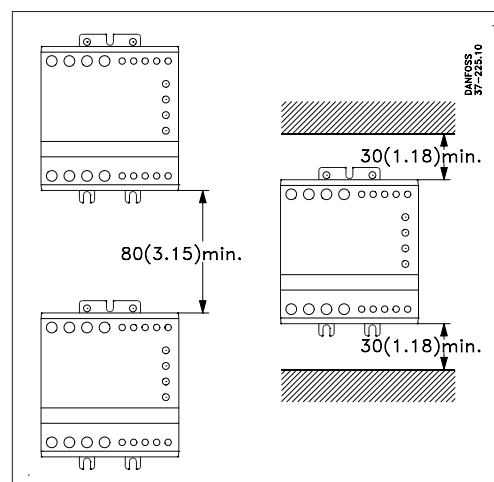

Application examples

Overheat protection

Example 1

The thermostat can be connected in series with the control input of the Motor Controller. When the temperature of the heat sink exceeds 100 °C the Motor Controller will be switched OFF.

Note: when the temp. has dropped approx. 30 °C the Controller will automatically be switched ON again. This is not acceptable in some applications

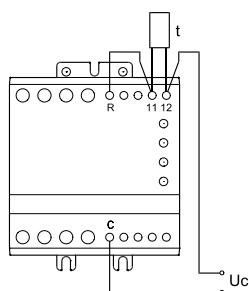

Example 2

The thermostat is connected in series with the control circuit of the main contactor. When the temp. of the heat sink exceeds 100 °C the main contactor will be switched OFF. This circuit requires manual reset to restart the motor.

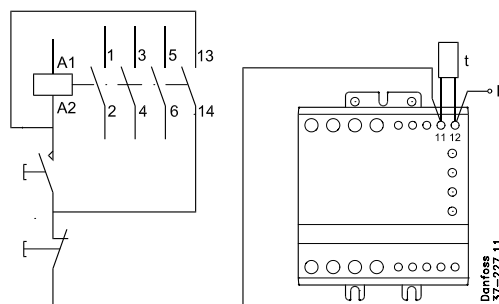

Standard start – brake wiring

If only the soft start and braking function is required it is easily achieved by wiring the control voltage to "R". When control voltage is applied the controller will begin the soft start procedure. To brake the load the control voltage is disconnected.

Danfoss circuit breaker CTI 25M is in this example providing overload and short circuit protection.

