

High Speed Milliohm Resistance Meter



- 20 mΩ to 23 MΩ wide resistance range
- 10 ms measurement time
- 0.03% accuracy
- 1 μΩ resolution
- Automatic thermal and electromagnetic noise rejection
- Programmable reference currents
- GPIB, RS-232C and RS-422 compatibility (Model: 1740/GPIB)



Finally a resistance meter that doesn't force the choice between accuracy and speed. The 1740 milliohm resistance meter is based on TEGAM's industry proven microhmeter platform for superior resistance measurement. Accuracy at high speed delivers more throughput with better yield. This improves your product quality and profitability.

It's Fast

The 1740 accelerates the high speed production line. In the Fast Mode the 1740 can set-up, zero-out thermal errors, acquire data and make its first reading in less than 12 milliseconds with an accuracy of up to 0.05%! Subsequent readings are provided every 10 milliseconds at a true rate of 100 readings per second!

The 1740 provides speed and accuracy while automatically rejecting thermal and line noise. Patented circuitry eliminates thermal and electromagnetic measurement errors caused by contact between device handlers and the device-under-test. The 1740 rejects DC and AC noise offsets while maintaining its high speed test performance.

It's High Powered

The 1740's power is in the user's ability to quickly configure it through a selection of standard setup menus. With the 1740 you select your measurement mode, (Resistance, Ohms Comparator or Percentage Comparator), and measurement ranges, (from 20 mΩ to 20 MΩ). You have your choice of reference currents and triggering methods. You can also configure delay times, settling times and automatic thermal and noise rejection. If you don't need all this flexibility, just hit the AUTO RANGE button and enjoy the ride!

It's Easy to Operate

The 1740 is the state-of-the-art programmable ohmmeter that operates via front-panel or over the bus. Clearly labeled multifunction keys provide front panel control of range selection, reading modes, delays, triggers and measurement HOLD. Clear menu driven options provide easy setup for more sophisticated operation, too! The Front panel includes a manual TRIGGER and HOLD function and HI/GO/LO indicators for the open collector TTL output.

It's Easy to Integrate

The 1740 is unbelievably easy to program. The 1740/GPIB contains a full complement of interfaces including IEEE-488, RS-232C and RS-422. To maximize your programming efficiency, each of these interfaces is operated using the same programming command set and front panel indicators to provide continuous status of all operations.

It's Easy to Calibrate

Front panel calibration makes it easy to maintain the 1740 traceability right on the product floor and in less time than it takes to reload a resistor reel.

It's Ready for Any Job

The 1740 provides the speed and accuracy desired for automated production test requirements as well as bench top quality control and inspection applications. Not only is the 1740 perfect for high speed production test of low resistance electronic components, but the low current capability and "TRUE-SPEED" performance make the 1740 excellent for dry circuit testing of switches, relays and connector contacts without disturbing the device's contact surfaces. 1740 fits most resistor, wire, fuse, thermistor and trimmer testing applications.

Table 1: Full Scale Voltage and Maximum Lead Resistance as a Function of Reference Current

RANGE	RESOLUTION	REFERENCE CURRENT (AVAILABLE SELECTION)						
		100 mA	10 mA	1 mA	100 μ A	10 μ A	1 μ A	100 nA
20 m Ω	1 $\mu\Omega$	2 mV						
200 m Ω	10 $\mu\Omega$	20 mV						
2 Ω	100 $\mu\Omega$	200 mV	20 mV					
20 Ω	1 m Ω		200 mV	20 mV				
200 Ω	10 m Ω		2 V	200 mV	20 mV			
2 k Ω	100 m Ω			2 V	200 mV			
20 k Ω	1 Ω				2 V	200 mV		
200 k Ω	10 Ω					2 V		
2 M Ω	100 Ω						2 V	
20 M Ω	1 k Ω							2 V
MAX. LEAD RESISTANCE:		5 Ω	50 Ω	100 Ω	100 Ω	100 Ω	100 Ω	100 Ω

TABLE 2
Delayed Mode Accuracy (In terms of FULL SCALE VOLTAGE)

FULL SCALE VOLTAGE	(\pm) ACCURACY (18-28°C, 1 yr.)
2 mV	0.02 % RDG + 5 COUNTS
20 mV	0.02 % RDG + 4 COUNTS
200 mV	0.02 % RDG + 2 COUNTS
2 V	0.02 % RDG + 2 COUNTS
2 V (2 M Ω & 20 M Ω ranges)	0.04 % RDG + 2 COUNTS

TABLE 3
Temperature Coefficients (In terms of FULL SCALE VOLTAGE)

FULL SCALE VOLTAGE	(\pm) TEMPERATURE COEFFICIENT (0-18 °C and 28-50 °C)
2 mV	0.004 % RDG + 1 COUNT
20 mV	0.004 % RDG + 0.5 COUNTS
200 mV	0.002 % RDG + 0.1 COUNTS
2 V	0.002 % RDG + 0.1 COUNTS
2 V (2 M Ω & 20 M Ω ranges)	0.008 % RDG + 0.5 COUNTS

FASTMODE ACCURACY is \pm (0.05 % + 5 COUNTS)

REFERENCE CURRENT MODES:

Fast Continuous:

Pulsing reference current (+REF/0), with automatic thermal and noise rejection.

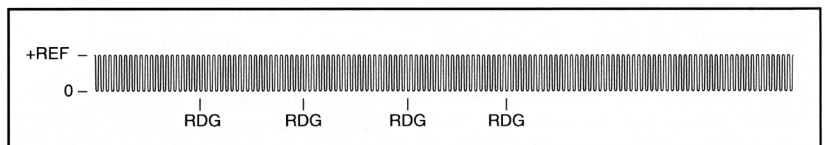

Fast One-Shot:

Triggered single cycle of Fast Continuous Mode.

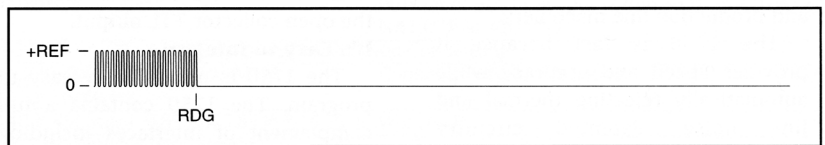

Delayed Continuous:

Alternating reference current (+REF/-REF) with programmable settling time for reference current and line-cycle digitization.

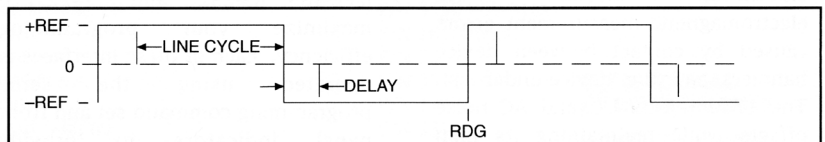

Delayed One-Shot:

Triggered single cycle of Delayed Continuous Mode.

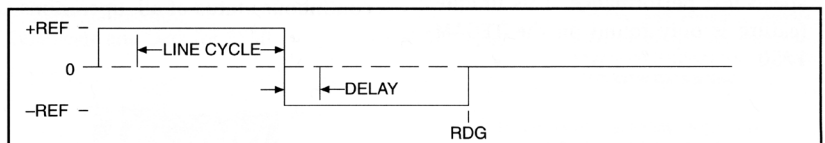

TABLE 4: Measurement Times

RANGE	FAST MODE v. FULL SCALE VOLTAGE				DELAYED MODE v. FULL SCALE VOLTAGE			
	2 mV	20 mV	200 mV	2 V	2 mV	20 mV	200 mV	2 V
20 mΩ					D	D		
200 mΩ						D	D	
2 Ω			F			D	D	
20 Ω			F			D	D	
200 Ω			F	F		D	D	D
2 kΩ			F	F			D	D
20 kΩ				F			D	D
200 kΩ								D
2 MΩ								D
20 MΩ								D

NOTES:

1. Fast Mode available on range and full scale voltage combinations shown, (F)
2. Delayed Mode available on combinations shown, (D).
3. Delayed Mode Measurement Times = 2 x (Line Period + Programmed Delay + 1.7 ms Processing Time). e.g. 60 Hz line frequency and 10 ms delay, Time = 55.0 ms.
4. Delays are programmable from 1 ms to 250 ms in 1 ms increments.

MISCELLANEOUS

Display Modes

Resistance, Ohms Comparator, % Comparator (Autoranging available in Resistance Mode)

Digital Interfaces

-TRIGGER IN and READING DONE via BNC connectors (standard)
 -IEEE-488.1, RS-232C, RS-422 (optional) (Model 1740/GPIB)

Display

4-1/2 digit alpha numeric readout, 2x16 characters, backlit LCD

Measurement Method

4 - terminal connection to the Device-Under-Test, (DUT)

Input Connector

Heavy duty LEMO type for interface integrity and long life

Input Protection

± 15 V continuous

Overload Current

Delay Mode: 100 % overshoot, < 25 μs
 Fast Mode: 200 % overshoot, < 30 μs

Noise Rejection

60 dB typical at line frequency

Environmental

Operating: 0 °C to +50 °C, < 80 % RH;
 Storage: -35 °C to +60 °C, < 90 % RH

Conformity

CE Class A: EN 55022, EN 61000-3-2, EN 61000-3-3

TABLE 5: Reading Rates

	MEASUREMENT TIMES	READING RATE	TIME TO FIRST READING
FAST MODE	10 ms	100 rdg/s	12 ms
DELAYED MODE			
Delay = 1 ms	36 ms	27 rdg/s	38 ms
Delay = 5 ms	45 ms	22 rdg/s	47 ms
Delay = 10 ms	55 ms	18 rdg/s	57 ms

Time to First Reading:

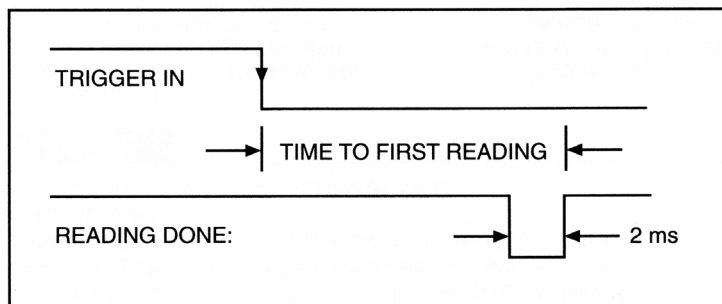

Power Requirement

<100 VA, 108-132 VAC or 216-264 VAC, at 50/60 Hz

Dimensions

13.3 cm x 21.7 cm x 33.0 cm
 (5.2 x 8.5 x 13.0 in) H X W X D

Weight

4.2 kg (9 lb. 4 oz)

Calibration

Full front panel calibration requires no internal adjustments and can be easily achieved on the production floor.

VOLTAGE AND RESISTANCE PRODUCTS

MKP/1750-5 Kelvin Probe

These probes are excellent for making four-wire surface resistance measurements on films and other flat metallic surfaces. The probes are marked indicating the sense pins, ensuring an operator error free measurement. Each probe has two spring-loaded, replaceable tips that can be easily removed and replaced. Variety of probe tips available. The test leads are 5 feet long and are terminated with a LEMO connector. Pin center to pin center is 0.11 in (0.28 cm).

Cable length - 5 ft

Available Pin Options: P/N MKP-B, MKP-F, MKP-H, MKP-J, MKP-LM (4 pins) (shown right)

(Pins are not included with the probe set and need to be ordered separately.)



MKP/1750-5 Probe Set with "B" Style Pins Installed

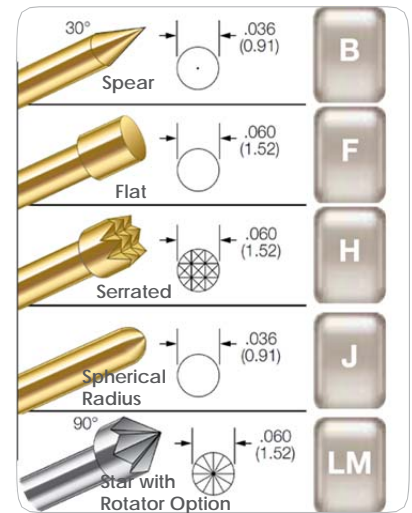

MKP/1750-5 Pin Options

MCP/1750-5 Kelvin Coaxial Probe

Ideal for precision resistance measurements in tighter spaces. The probe has a spring-loaded center pin for voltage detection, while the outer pin provides the reference current. The probe comes with two pins installed. The pins are replaceable. The test leads are 5 feet long and are terminated with a LEMO connector. Outer pin diameter is 0.06 in (0.15 cm). The inner tip diameter is 0.4 mm.

Cable length - 5 ft

Replaceable Pin Option: P/N MCP-A (2 pins)



MCP/1750-5 Probe with Coaxial Pins Installed

17501 Kelvin Klip Leads

Provides a solid four-terminal connection to components under test. These clips are particularly useful for manual resistance measurement. Max jaw opening is 0.65 in. Cable length – 3 ft



KK100 Kelvin Klip Rebuild Kit

Kelvin Klip replacements for construction or repair of Kelvin Klip leads. The Kit includes slip shrink sleeving, tubing, Klip halves, and insulating spools to build two Kelvin Klips.



17502 Spade Lug Adapter

Used for connections between the 1740/1750 front panel LEMO and existing test fixtures. Cable length – 3 ft



17503 Sorting Fixture

This sorting fixture allows for efficient four-wire measurement of leaded parts. The test fixture features spring action contacts for easy insertion and removal of test components. Cable length – 3 ft



17505 Male LEMO Connector & Strain Relief

For the repair or construction of 1740/1750 test leads.



17506-5 LEMO to Bare Wire

These probes have a LEMO connector at one end and four bare wires on the other. Cable length – 5 ft



17507 Large Kelvin Klip Leads

Provides a solid 4-terminal connection to large components that cannot be measured with conventional Kelvin clips. It is robust in construction, ensuring a firm grip. Used for connection with large bolts, cables, plates, etc. Cable length – 8 ft



SKT/1750-5 Chip Tweezers

Four-terminal tweezers make solid connections to chip components in manual sorting applications. Capacity of jaws is 12.7 mm (0.5 in). Contact tips are replaceable. Cable length – 5 ft

Available Tip Kits: P/N 47422 (two wire straight), 47423 (four wire straight), 47424 (four wire angled) A tip kit includes 12 tips, two screws, and one Allen wrench.



CA-22-36 RS-232 Straight Cable

Male to Female DB9-DB9 straight cable used to connect the 1740/GPIB or 1750 to a PC via RS-232. Cable length – 3 ft



1583 GPIB (IEEE-488) Cables

The cable can be used to connect the 1740/GPIB or 1750 to a PC via GPIB.

1583-3 – 3 ft GPIB buss cable **1583-6** – 6 ft GPIB buss cable **1583-9** – 9 ft GPIB buss cable

