

## MINI BALL VALVE MODEL MBV

Illustrated model: MBV25R

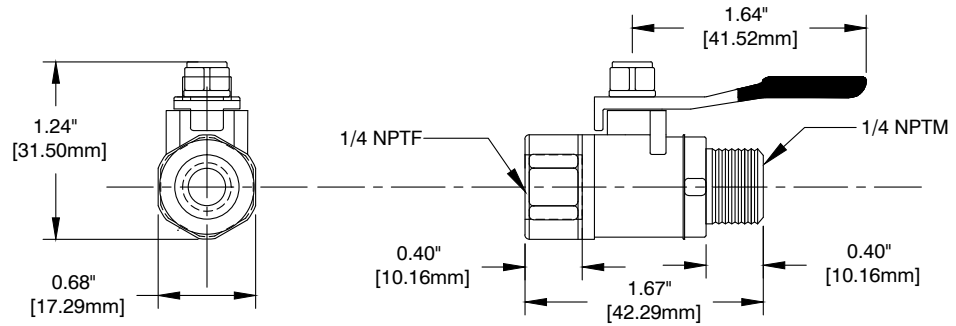
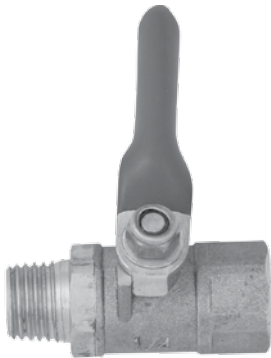

Diagram: MBV25L

Product code:	MBV25L	MBV25R
Housing:	Brass	
Packing:	Teflon	
Connection:	1/4 in nptf x 1/4 in nptm	
Opening:	Left turn	Right turn
Maximum operating pressure:	600 psi / 4,137 kPa	600 psi / 4,137 kPa
Maximum operating temperature:	250°F / 120°C	250°F / 120°C

### Applications

The mini ball valve is an economical way to protect and stop the flow of air or fluid into the pressure gauge. It is always recommended to install a mini ball valve or a needle valve on a line before each pressure gauge installation.