

Data sheet

2 - way valve (NC), pressure relieved (PN 25)

VGU - external thread

VGUF- flange

Description



VGU and VGUF are pressure relieved 2-way normally closed (NC) valves, designed to be combined with:

- AVT Temperature actuators
- AMV(E) 20 / AMV(E) 30 electrical actuators
- AMV(E) 23 / AMV(E) 33 electrical actuators with spring return function

In combination with AVT temperature actuators and AMV(E) electrical actuators, valves can be used primarily in cooling systems

Main data:

- DN 15-50
- k_{vs} 4.0 -25 m³/h
- PN 25
- Temperature:
 - Circulation water / glycolic water up to 30%: 2 ...150 °C
- Connections:
 - Ext. thread (weld-on, thread and flange tailpieces)
 - Flange
- Flow and return mounting

Ordering

Example:
Valve NC; DN 15; k_{vs} 4.0; PN 25;
 T_{max} 150 °C; ext. thread

- 1x VGU DN 15 valve
Code No: **065B0791**

Option:
- 1x Weld-on tailpieces
Code No: **003H6908**

VGU, VGUF valve

Picture	DN (mm)	k_{vs} (m ³ /h)	Connection	Code No.
	15	4.0	Cylindrical external thread acc. to ISO 228/1	G ¾ A 065B0791
	20	6.3		G 1 A 065B0792
	25	8.0		G 1¼ A 065B0793
	32	12.5		G 1¾ A 065B0794
	40	16		G 2 A 065B0795
	50	20		G 2½ A 065B0796
	32	12.5	Flanges PN 25, acc. to EN 1092-2	065B0797
	40	20		065B0798
	50	25		065B0799

Ordering (continuous)

Accessories

Picture	Type designation	DN	Connection	Code No.
	Weld-on tailpieces	15	-	003H6908
		20		003H6909
		25		003H6910
		32		003H6911
		40		003H6912
		50		003H6913
	External thread tailpieces	15	Conical ext. thread acc. to EN 10226-1	R 1/2 003H6902
		20		R 3/4 003H6903
		25		R 1 003H6904
		32		R 1 1/4 003H6905
		40		R 1 1/2 065F6061
		50		R 2 065F6062
	Flange tailpieces	15	Flanges PN 25, acc. to EN 1092-2	003H6915
		20		003H6916
		25		003H6917
	Adapter ¹⁾		M45 x 1.5 mm / M30 x 1.5 mm	003H6928

¹⁾ Adapter for VGU(F) combinations with electrical actuators type AMV(E) 20, 23, 30, 33.

Technical data

Valves

Nominal diameter	DN	15	20	25	32	40	50
k _{vs} value	m ³ /h	4.0	6.3	8.0	12.5	20	25
Stroke	mm	5					
Control ratio		>1:50					
Control characteristic		linear					
Cavitation factor z		≥ 0.6		≥ 0.55		≥ 0.5	
Leakage acc. to standard IEC 534	% of k _{vs}	≤ 0.02			≤ 0.05		
Nominal pressure	PN	25					
Max. differential pressure	bar	20			16		
Media		Circulation water / glycolic water up to 30%					
Media pH		Min. 7, max. 10					
Media temperature	°C	2 ... 150					
Connections	valve	External thread			External thread and flange		
	tailpieces	Weld-on and external thread					
		Flange			-		
Materials							
Valve body		Red bronze CuSn5ZnPb (Rg5)			Ductile iron EN-GJS-400-18-LT (GGG 40.3)		
Valve seat		Stainless steel, mat. No. 1.4571					
Valve cone		Dezincing free brass CuZn36Pb2As					
Sealing		EPDM					
Pressure relieve system		Piston					

Application principles

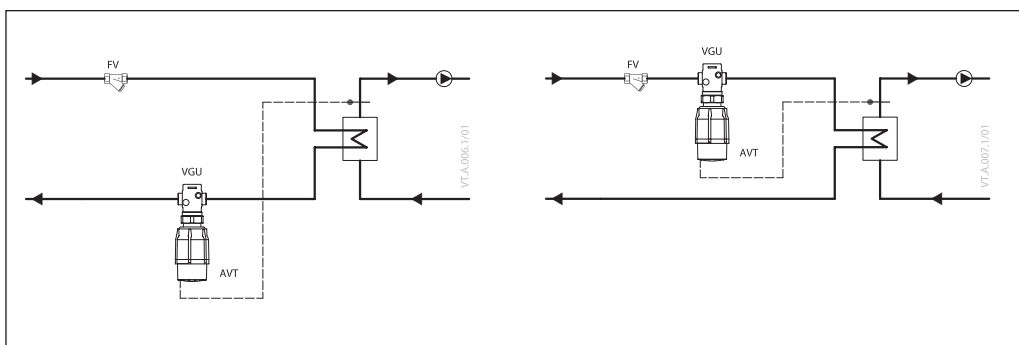

Installation positions

Valves can be installed in any position.

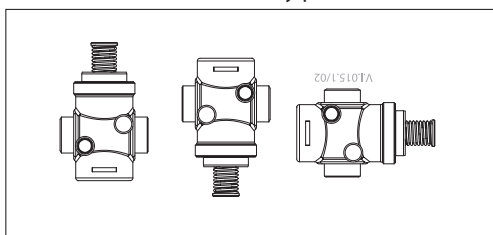

Note!

Installation positions for AVT thermostatic actuator and electrical actuators AMV(E) have to be observed as well. Please see relevant Data sheet

Pressure temperature diagram

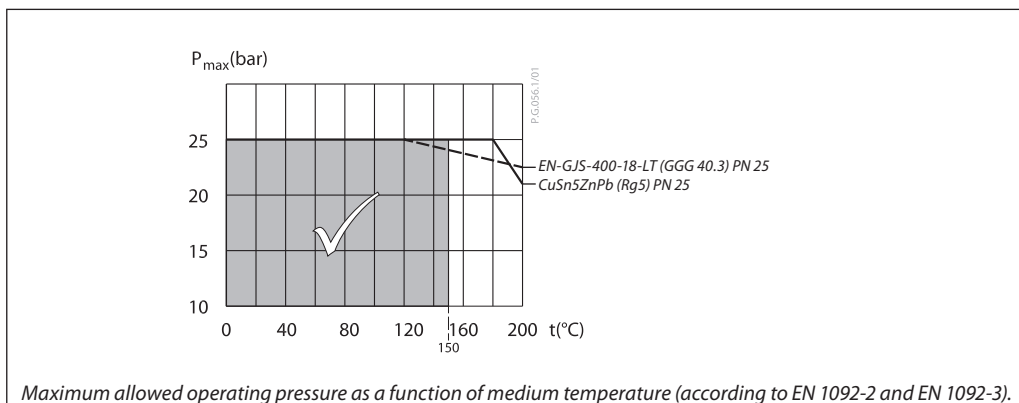

Valve sizing

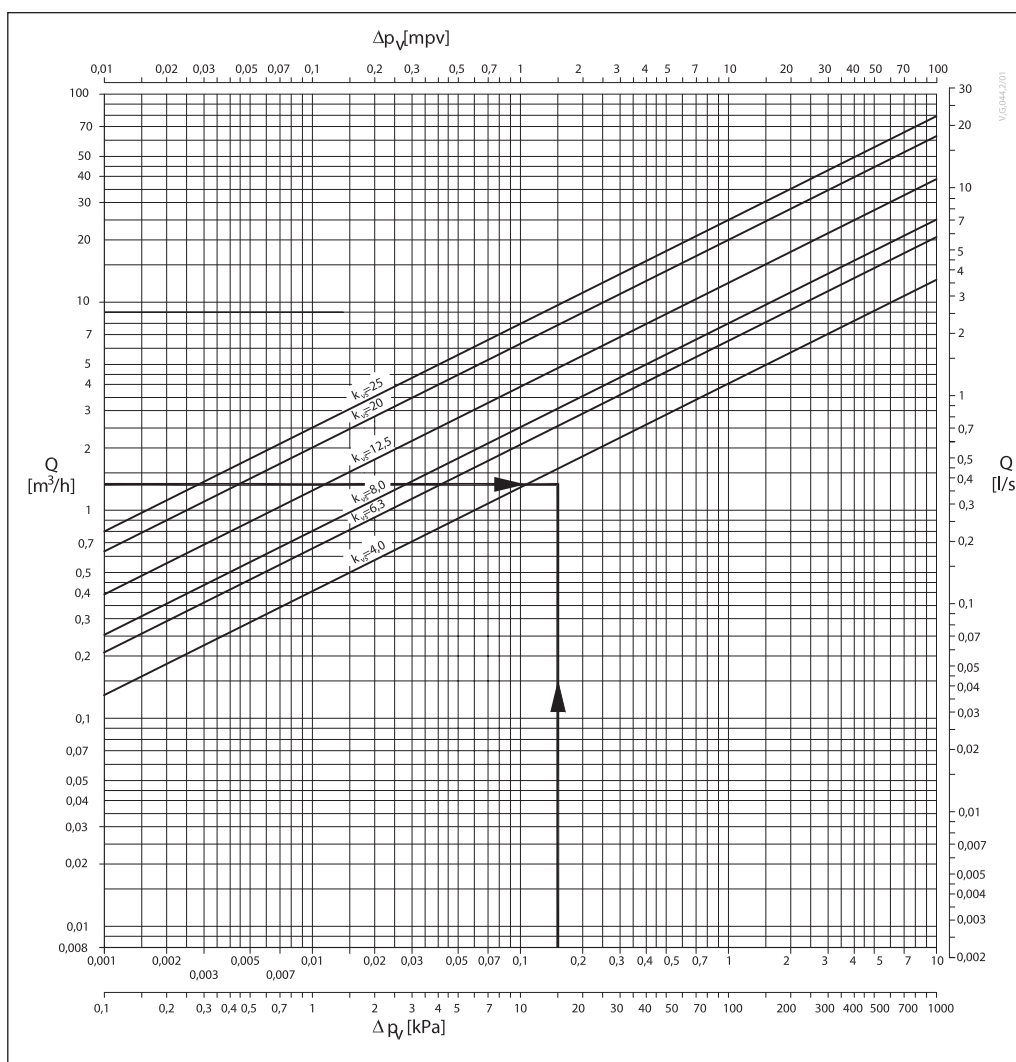

Given data:

$P_{max} = 10 \text{ kW}$
 $\Delta t = 6 \text{ K}$
 $\Delta p_v = 0.15 \text{ bar}$

P_{max} - cooling power (kW)
 Δt - temperature difference (K)
 Δp_v - differential pressure across the valve

Maximum flow Q_{max} (m³/h) through the valve is calculated according to formula:

$$Q_{max} = \frac{P_{max} \times 0.86}{\Delta t} = \frac{10 \times 0.86}{6}$$

$$Q_{max} = 1.43 \text{ m}^3/\text{h}$$

k_v value is calculated according to formula:

$$k_v = \frac{Q_{max}}{\sqrt{\Delta p_v}} = \frac{1.43}{\sqrt{0.15}}$$

$$k_v = 3.7 \text{ m}^3/\text{h}$$

Chosen $k_{vS} = 4.0 \text{ m}^3/\text{h}$

or

read from the sizing diagram by taking a line through Q scale (1.43 m³/h) and Δp_v scale (0.15 bar) to intersect k_v -scale at 3.7 m³/h

Chosen $k_{vS} = 4.0 \text{ m}^3/\text{h}$

Solution:

The example selects ext. thread valve VGU DN 15, k_{vS} value 4.0 .

Design

- 1. Valve body
- 2. Valve insert
- 3. Pressure relieved valve cone
- 4. Valve stem

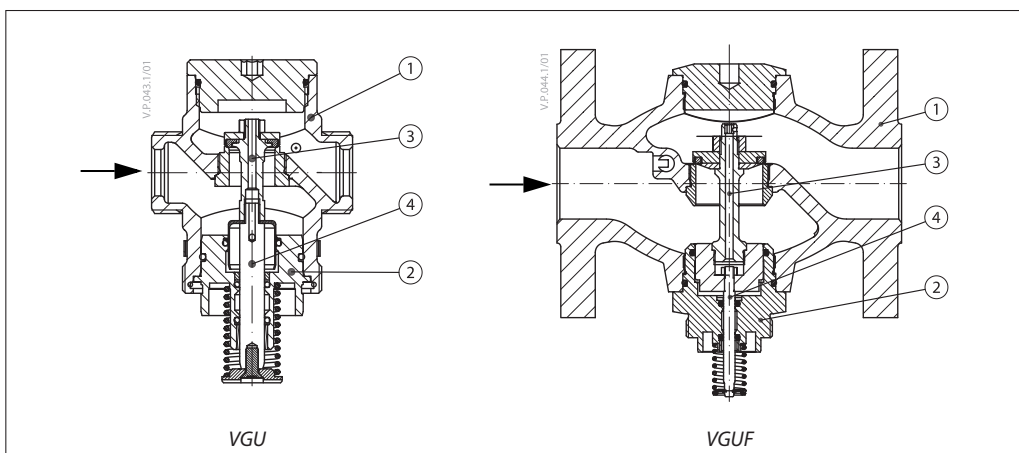

Dimensions

VGU DN 15-25

VGU DN 32-50

VGUF DN 32-50

VGU

DN	L	H	H ₁	H ₂	Weight (kg)
15	65	80	34	46	0.7
20	70	80	34	46	0.8
25	75	83	37	46	0.9
32	100	154	63	91	3.2
40	110	154	63	91	3.3
50	130	154	63	91	4.1

VGUF

DN	L	H	H ₁	H ₂	Weight (kg)
32	180	158	70	88	7.5
40	200	163	75	88	9.0
50	230	171	83	88	11.1

Note: other flange dimensions - see table for tailpieces

SW

SW

SW

SW

DN	R ¹⁾	SW	d	L ₁ ²⁾	L ₂	L ₃	k	d ₂	n
15	1/2	32 (G 3/4A)	21	130	131	139	65	14	4
20	3/4	41 (G 1A)	26	150	144	154	75	14	4
25	1	50 (G 1 1/4A)	33	160	160	159	85	14	4
32	1 1/4	63 (G 1 3/4A)	42	-	177	184	100	18	4
40	1 1/2	70 (G 2A)	47	-	195	204	110	18	4
50	2	82 (G 2 1/2A)	60	-	252	234	125	18	4

Adapter VGU/AMV(E)

¹⁾ Conical ext. thread acc. to EN 10226-1

²⁾ Flanges PN 25, acc. to EN 1092-2

